

HAZET – Hammers · Chisels · Center Punches

- ✓ Machinist's Hammer
- ✓ Ball Peen Hammer
- ✓ Rubber Hammer
- ✓ Chisels
- ✓ Drift Punches
- ✓ Drift Pins, Center Punches, and many more ...

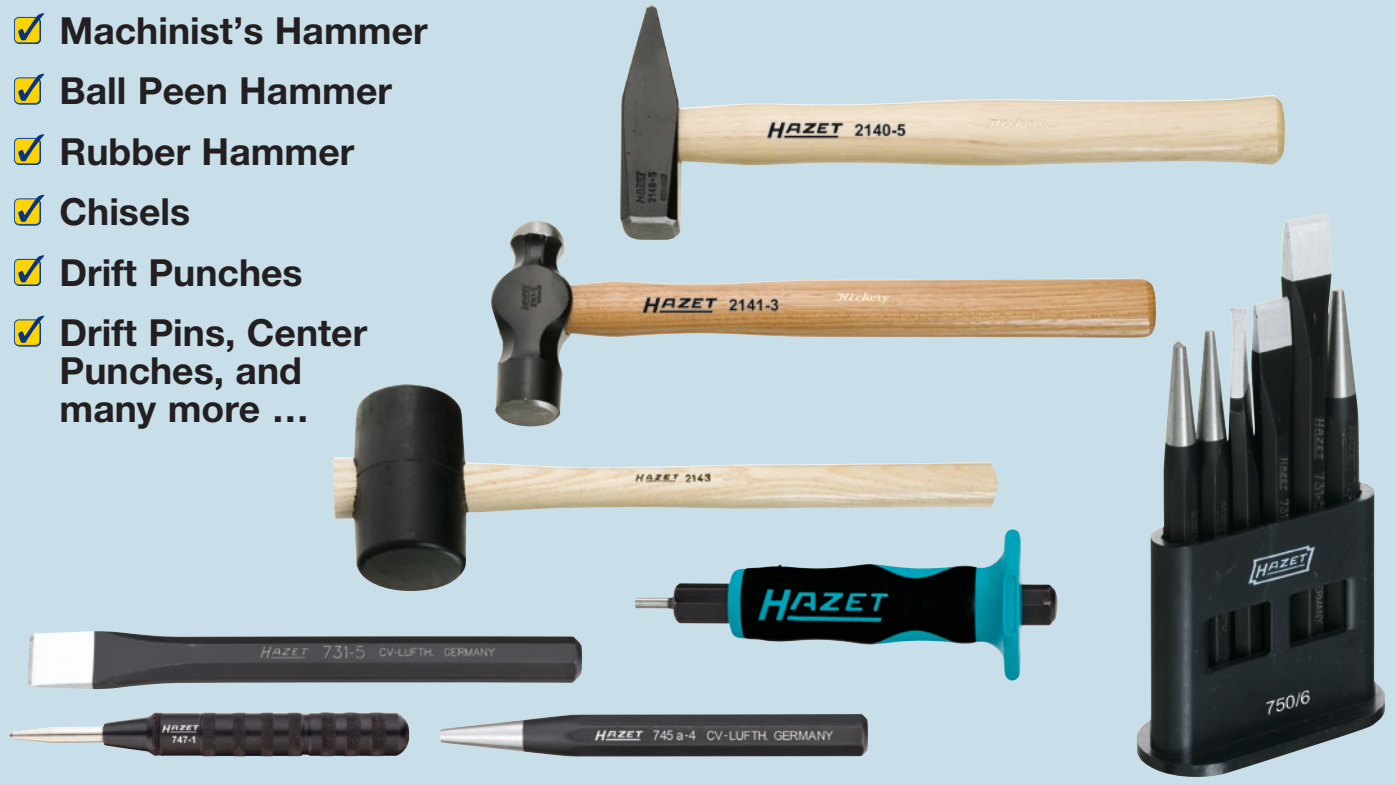

Hammers · Chisels · Center Punches

Machinist's Hammer



- Quality grade A
- Hickory handle
- DIN 1041

Made in Germany

HAZET No.	l mm	Weight	EAN-No. 4000896+
2140- 2	280	200 g	012640
2140- 3	300	300 g	012657
2140- 4	310	400 g	012688
2140- 5	320	500 g	012695
2140- 8	350	800 g	012725
2140-10	360	1000 g	012633

Plastic Hammer



- Replaceable Desmopan® heads with low rebound
- Joint-protecting, ergonomic handle
- Environmentally friendly and breathable ash wood handle
 - surface treated with natural wax
 - high sweat absorption
- Zinc-cast center part with protective guide bush for the handle

Made in Germany

HAZET No.	Ø mm	EAN-No. 4000896+
1952-28	28	008506
1952-35	35	008520
1952-40	40	008544
1952-50	50	008551

Spare Head

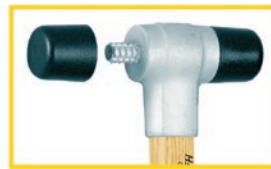

- Made of extremely tough Desmopan® material
- To remove worn-out heads turn to the left.
- Bump on new head with a hammer or by pressure without turning.

Made in Germany

HAZET No.	Ø mm	EAN-No. 4000896+
Spare Heads (pair) for 1952-28		
1952-028	28	008391
Spare Heads (pair) for 1952-35		
1952-035	35	008414
Spare Heads (pair) for 1952-40		
1952-040	40	008438
Spare Heads (pair) for 1952-50		
1952-050	50	008452

Plastic Hammer



- **Non-rebound:** due to steel-ball filling in the center part of the hammer head and the special material of impact heads
- Replaceable hammer heads made of special plastic material, splinterproof and non-crumbing

Plastic Hammer

- Gentle and careful working
- Abrasion-proof, long service-life
- Steel tube handle
- Plastic handle cover, resistant to oil and gasoline

Made in Germany

HAZET No.	l mm	Ø mm	EAN-No. 4000896+
1953-30	113	30	008636
1953-35	115	35	008650
1953-40	123	40	008667
1953-50	133	50	008681
1953-60	163	60	008698

Spare Head



- Special plastic material, splinterproof and non-crumbing
- Cramp worn-out head in a vice and twist to remove.
- Use a hammer to bump on new head.

Made in Germany

HAZET No.	Ø mm	EAN-No. 4000896+
Spare Heads (pair) for 1953-30		
1953-030	30	008575
Spare Heads (pair) for 1953-35		
1953-035	35	008582
Spare Heads (pair) for 1953-40		
1953-040	40	008599
Spare Heads (pair) for 1953-50		
1953-050	50	008612
Spare Heads (pair) for 1953-60		
1953-060	60	008629



Hand Tools – Hammers · Chisels · Center Punches

Ball Peen Hammer



- Hickory handle
- **Made in Germany**

HAZET No.	l mm	Weight	EAN-No. 4000896+
2141-2	360	1 lbs	012763
2141-4	380	2 lbs	012787

Rubber Hammer



- 54 mm Ø x 90 mm
- DIN 5128

HAZET No.	l mm	Weight	EAN-No. 4000896+
2143	320	225 g	012794

Flat Chisel

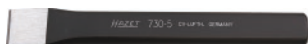

- Rectangular stock
- DIN 6453
- **Made in Germany**

HAZET No.	l mm	W mm	EAN-No. 4000896+
730-2	125	15	029563
730-3	150	18	029570
730-4	150	21	029587
730-5	175	21	029594
730-6	200	24	029600
730-7	250	25	029617
730-8	300	26	029624



- **Made in Germany**

HAZET No.	EAN-No. 4000896+
730 HS	029631

- Hand guard for Flat Chisel 730-6, -7, -8
- Made of shock-resistant plastic

Flat Chisel



- Octagonal stock
- **Made in Germany**

HAZET No.	l mm	W mm	EAN-No. 4000896+
731-2	125	11	029648
731-5	150	15	029655

Cape Chisel

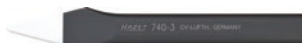

- Rectangular stock
- DIN 6451
- **Made in Germany**

HAZET No.	l mm	W mm	EAN-No. 4000896+
740-3	150	6	029679



- Octagonal stock
- **Made in Germany**

HAZET No.	l mm	W mm	EAN-No. 4000896+
741-1	125	4	029709



Your commercial vehicle specialist!



Drift Punch



- Light design (B)
- Octagonal stock
- Surface: matt black
- DIN 6458

Made in Germany

HAZET No.	l mm	Ø mm	EAN-No. 4000896+
745-1	120	1	029716
745-2	120	2	029723
745-3	120	3	029730



- Heavy design (D)

Made in Germany

HAZET No.	l mm	Ø mm	EAN-No. 4000896+
745 a-2	120	2	029778
745 a-3	120	3	029785
745 a-4	120	4	029792
745 a-5	120	5	029808
745 a-6	120	6	029815

Centre Punch



- Octagonal stock
- DIN 7250

Made in Germany

HAZET No.	l mm	Ø mm	EAN-No. 4000896+
746-1	120	10	029846
746-2	120	12	029853

Auto-Impact Centre Punch



- Impact force 3 to 30 kg
- Progressively adjustable
- Tough punch tip
- The impact force is applied by simply pressing down the upper part

Made in Germany

HAZET No.	l mm	EAN-No. 4000896+
747-1	135	051434
Punch tip for 747-1		
747-02	-	051380

Drift Pin



- Octagonal stock
- DIN 6450 form C

Made in Germany

+ = long style

HAZET No.	l mm	Ø mm	EAN-No. 4000896+
748 a- 2	115	2	029884
748 a- 3	125	3	029891
748 b- 2	150	2	029907
748 b- 3	150	3	029914
748 b- 4	150	4	029921
748 b- 5	150	5	029938
748 b- 6	150	6	029945
748 b- 8	150	8	029952
748 c- 6 +	180	6	029976
748 c- 8 +	200	8	029983
748 c-10 +	200	10	029969

Drift Pin



Made in Germany

HAZET No.	l mm	Ø mm	Ø mm	EAN-No. 4000896+
-----------	------	------	------	------------------

- Especially for safety bolts on rear disc brakes MERCEDES-BENZ E-Class 211

- Ø 3 mm

748 Lg b-3 175 3 10 100040

- Especially for safety bolts on disc brakes

- Ø 4 mm

748 Lg b-4 175 4 10 029990

Chisels, Drift Punches, Center Punches



- Sets with 6 pieces
- In plastic display stands

Made in Germany

HAZET No.	EAN-No. 4000896+
-----------	------------------

Contents:
731-2 5 741-1 745 a-4 745-3 746-1
750/6 030026

Contents:
730-3 6 740-3 745 a-4 745-2 746-2
750/6-1 030033

Drift Pin Set



- Sets with 6 pieces
- In plastic display stands

Made in Germany

HAZET No.	EAN-No. 4000896+
-----------	------------------

Contents:
748 a-2 3 748 b-4 5 748 c-6 8
751/6 030088

Contents:
748 b-2 3 4 5 6 8
751/6-1 030095

Brass Mandrel



- For driving bushings, bearings, bolts, etc. in and out

Made in Germany

HAZET No.	l mm	Ø mm	EAN-No. 4000896+
2534	200	20	016365

Drift Pin Set



- 2-component hand guard cover adapted to hand shape guarantees:
 - Less risk of injury
 - Depressant effect (less stress to the hand due to impacts)
 - Safe gripping

Contents:
5 3 4 5 6 8 mm

- Total length: 150 mm, length hand guard: 75 mm
- DIN 6450 form C

Made in Germany

HAZET No.	EAN-No. 4000896+
751 HS/5	148257

Drift Pin, short

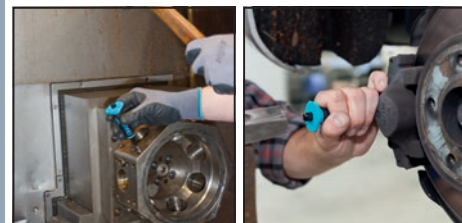

- Short design with hand guard
- For hitting (loosening) the slide bolts when removing the brake calliper's brake pads e.g. on MERCEDES-BENZ
- Total length 109 mm
- Blade length 10 mm

Made in Germany

HAZET No.	l mm	Ø mm	EAN-No. 4000896+
751 KHS-3	109	3	159987
751 KHS-4	109	4	159994

Grinding, Separation and Cutting

- ✓ Marking Tools
- ✓ Welding Spot Drills and Cutters
- ✓ Twist Drill Bits
- ✓ Three Square, Flat Hand, Half Round, Round Files
- ✓ Saws and many more ...



Twist Drill Bits in Case



- 25 pieces, \varnothing 1–13 mm, increasing by 0.5 mm
- 118° standard point
- DIN 338

HAZET No.	EAN-No. 4000896+
2128-1	103775

Welding Spot Drill



- For marking metal and other materials with smooth surfaces
- Surface: burnished

HAZET No.	l mm	EAN-No. 4000896+
2150	240	013012

Welding Spot Drill



- For exact welding spot reaming in sheet metal fabrication
- No warped or torn materials
- 7 mm hexagon shank prevents slippage in drill chuck
- Fits power drills of all types
- Replaceable cutting crown (right-hand thread) made of high-speed steel (oiled)
- Cutting crown for use at both ends
- With screw for gauge depth adjustment (*)

Made in Germany

HAZET No.	\varnothing mm	l mm	EAN-No. 4000896+
1967	11	70	009312



Cutter crowns, set of 10 pieces for 1967

1967-01	-	-	009329
---------	---	---	--------

Center tip for 1967

1967-02	-	-	009336
---------	---	---	--------

Marking Tool



- For marking metal and other materials with smooth surfaces
- Surface: burnished

HAZET No.	l mm	EAN-No. 4000896+
2150	240	013012

Marking Tool



- For marking metal and other materials with smooth surfaces
- Special steel for long-lasting use
- With practical clip

HAZET No.	l mm	EAN-No. 4000896+
2150-1	150	144129

Welding Spot Drill



- For exact welding spot reaming
- Self-cutting centring tip resharpenable
- Heavy duty, high-speed steel, blued

Made in Germany

HAZET No.	l mm	\varnothing mm	EAN-No. 4000896+
1967-70	74	7	009343
1967-80	79	8	009350
1967-90	79	9	009367

Half Round File



- Half round
- Teeth (cut): 2 = medium
- Plastic handle
- DIN 7261 form E

HAZET No.	l mm	EAN-No. 4000896+
2119- 8	200	012398
2119-10	250	012381

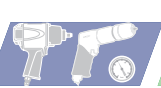

Round File



- Round
- Teeth (cut): 2 = medium
- DIN 7261 form F

HAZET No.	l mm	EAN-No. 4000896+
2120- 8	200	012411
2120-10	250	012404

Flat Hand File



- Flat
- Teeth (cut): 2 = medium
- DIN 7261 form A

HAZET No.	l mm	EAN-No. 4000896+
2122- 8	200	012435
2122-10	250	012428

Three Square File



- Three square
- Teeth (cut): 2 = medium
- DIN 7261 form C

HAZET No.	l mm	EAN-No. 4000896+
2123- 8	200	012473
2123-10	250	012466

Hack Saw



- With blade tensioning end screw
- Plastic handle and front bow
- With 1 saw blade
- For 300 mm saw blades

HAZET No.	l mm	EAN-No. 4000896+
1980 N	390	009824

Hack Saw

HAZET No.	l mm	EAN-No. 4000896+
-----------	------	------------------

Saw blade

- 24 teeth/inch
- 300 mm long
- One-sided
- Fully hardened and elastic

1980 B-2	300	009817
----------	-----	--------

Small Hack Saw



- For saw blades 150 mm
- With 1 saw blade
- Handle made of glass fiber reinforced plastic
- Special steel St 2 K 40
- **Made in Germany**

HAZET No.	l mm	EAN-No. 4000896+
1981	252	009831

- **Saw blade** for 1981, made of chrome-alloyed tool steel

1981-01	-	009848
---------	---	--------

Thread Repair



Screw Extractor



- For turning out worn screws and bolts with right-hand thread
- Ground

Made in Germany

HAZET No.	Ø mm	M	EAN-No. 4000896+
840-1	1.4–3.6	3–6	035687
840-2	2.1–4.9	6–8	035694
840-3	3.1–6.5	8–11	035700
840-4	4.8–8.8	11–14	035717
840-5	6.2–11	14–18	035724
840-6	9.4–15	18–24	035731
840-7	12.7–19	24–33	035748
840-8	17.5–24	33–45	035755

Screw Extractor Set



- In plastic box
- **Made in Germany**

HAZET No.	EAN-No. 4000896+
5 pieces	
Contents:	
840-1 2 3 4 5	
840/5	035762

Screw Extractor Set

HAZET No.	EAN-No. 4000896+
-----------	------------------

8 pieces

Contents:
840-1 2 3 4 5 6 7 8

840/8	035786
-------	--------

Stud Extractor Set

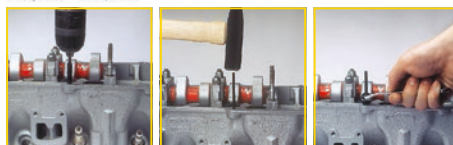
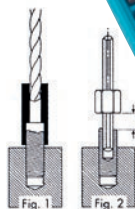

- For turning out broken bolts and screws
- Ø 6 to 15 mm
- Application:
 1. Bore up with drill and tapping sleeve
 2. Insert grooved stud extractor
 3. Put on union nut and screw out broken bolt or screw
- Surface: burnished

Stud Extractor Set

HAZET No.	EAN-No. 4000896+
-----------	------------------

- Set of 25 pieces in plastic box

841/25	060993
--------	--------

Union Nuts

841-01	074433
841-02	074440
841-03	074457
841-04	074464
841-05	074471

Tapping Sleeves

841-06	074488
841-07	074495
841-08	074501
841-09	074518
841-010	074525
841-011	074532
841-012	074549
841-013	074556
841-014	074563
841-015	074570

Stud Extractors

841-016	074587
841-017	074594
841-018	074600
841-019	074617
841-020	074624

Tapping Sleeve	Drill-Ø mm	Stud Extractor	Suitable for
841-06	4	841-016	M 5 3/16"
841-07	4	841-016	M 6 9/32" 1/4"
841-08	4	841-016	M 7 9/32"
841-09	4	841-016	M 8 5/16"
841-010	5	841-017	M 8 5/16"
841-011	5	841-017	M 9 11/32"
841-012	5	841-017	M10 3/8"
841-013	6	841-018	M11 7/16"
841-014	7.5	841-019	M12 15/32"
841-015	8.5	841-020	M14 9/16"

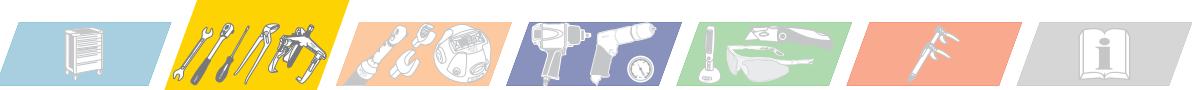

Thread Repair

Universal Thread Repair Tool



- For thread diameter 4–13 mm (5/32" – 1/2")**
- Quick fixation due to adjusting screw
 - Blade automatically adapts to any thread pitch within range
 - Repairs right- and left-hand threads (observe direction of rotation!)
 - Applicable to all forms of metric and non-metric threads

HAZET No.	M	EAN-No. 4000896+
842 AG-1	4–13 mm / 5/32" – 1/2"	140718



- For thread diameter 16–38 mm (5/8" – 1 1/2")**
- Quick fixation due to adjusting screw
 - Blade automatically adapts to any thread pitch within range
 - Repairs right- and left-hand threads (observe direction of rotation!)
 - Applicable to all forms of metric and non-metric threads

HAZET No.	M	EAN-No. 4000896+
842 AG-3	16–38 mm / 5/8" – 1 1/2"	149230

Universal Thread Repair Tool Set



- **For outside thread 4–13 mm (5/32" – 1/2") and inside thread 5–12 mm (1 3/64" – 1/2")**
- Simple and quick fixation due to knurled screw
- Manual operation will suffice
- Also suitable for aluminium threads
- Repairs right- and left-hand threads
- Applicable to all forms of metric and non-metric threads

HAZET No.	EAN-No. 4000896+
842 AIG-1/4	153428

Thread Repair Tool Set

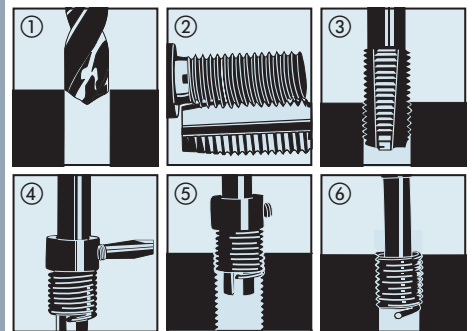

- For the repair of damaged or worn-out threads
- Thread reinforcement of materials presenting a low shearing resistance. Application e.g. in machine construction, automotive engineering, electrical and medical engineering
- Reuse of rejects
- High-quality chrome-nickel stainless steel provides good inside threads resisting the influences of weathering and corrosion
- In plastic case with insert

HAZET No.	EAN-No. 4000896+
---------------------	---------------------

- 130 pieces** M5 up to M12
Contents:
25 threaded inserts each
M 5 x 0.80 mm x 7.5 mm
M 6 x 1.00 mm x 9.0 mm
M 8 x 1.25 mm x 12.0 mm
M10 x 1.50 mm x 15.0 mm
10 threaded inserts
M12 x 1.75 mm x 1.5 x 18.0 mm
5 twist drills
5 taps
5 installation tools
5 pin breaking tools

842 N-512/130	167289
----------------------	--------

- 118 piece**, M6 up to M14
M14 esp. suitable for spark plugs
Contents:
25 threaded inserts each
M 6 x 1.00 mm x 9.0 mm
M 8 x 1.25 mm x 12.0 mm
M10 x 1.50 mm x 15.0 mm
10 threaded inserts
M 12 x 1.75 mm x 18.0 mm
5 threaded inserts each
M14 x 1.25 mm x 8.4 mm
M14 x 1.25 mm x 12.4 mm
M14 x 1.25 mm x 16.4 mm
4 twist drills
5 taps
5 installation tools
4 pin breaking tools

842 N-614/118	167272
----------------------	--------



**Reliable Tools
for Renewable Energies!**



Hand Tools - Thread Repair

Stud Extractor



12.5 1/2"

- For installing and removing stud bolts and set screws with right-hand or left-hand thread without damage
- □ drive 12.5 = 1/2" or ≤ 21 mm outside hexagon
- Surface: chrome-plated, polished

Made in Germany

HAZET No.	l mm	Ø mm	l ₂ mm	EAN-No. 4000896+
844- 6	65	23	6	035823
844- 7	65	23	7	035830
844- 8	65	23	8	035847
844-10	75	27	10	035809
844-12	75	27	12	035816

Stud Extractor Set



187 x 125 x 39 mm



- In plastic box
- With PUR foam insert

Made in Germany

HAZET No.	EAN-No. 4000896+
5 pieces	
Contents:	
844-6 7 8 10 12	
844/5	035878

Hydraulic Nut Splitter



- For splitting tight nuts of the quality ranges 5, 6, 8 and 10

HAZET No.	Ø mm	EAN-No. 4000896+
846-22 A	7-22	140435
846-36 A	22-36	140442

Mechanical Nut Splitter



- For splitting tight nuts of the quality ranges 5 and 6

Made in Germany

HAZET No.	Ø mm	EAN-No. 4000896+
847-0410 A	7-16	139903
847-1027 A	13-24	139910
847-1736 A	21-36	139927



Spare chisel for 847-0410 A and 1027 A

847-10 A - 144150

Spare chisel for 847-1736 A

847-17 A - 144167

Tap and Die Set



279 x 121 x 47 mm

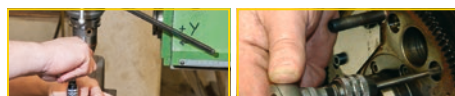

Tap and Die Set

Heavy-duty thread cutter made of HSS steel

- For problem-free rethreading even in areas with restricted access
- To be used with reversible ratchet
- In plastic box
- With PUR foam insert

HAZET No.	EAN-No. 4000896+

Contents:

849 IG- M3 M4 M5 M6 M8 M10 M12	
849 AG-M3 M4 M5 M6 M8 M10 M12	
849 IG-6,3 8	
849 AG-6,3 10	
2100-025 2250-1 3	
849	035984

Spare Parts

Dies for male threads

849 AG-M 3	036035
849 AG-M 4	036042
849 AG-M 5	036059
849 AG-M 6	036066
849 AG-M 8	036073
849 AG-M 10	036011
849 AG-M 12	036028

Taps for female threads

849 IG-M 3	036127
849 IG-M 4	036134
849 IG-M 5	036141
849 IG-M 6	036158
849 IG-M 8	036165
849 IG-M 10	036103
849 IG-M 12	036110

Made in Germany

HAZET No.	S mm	l mm	l ₁ mm	l ₂ mm	EAN-No. 4000896+

Chuck

- 6,3 = 1/4", for taps
- 849 IG-M 3 up to M 6 (in conjunction with adapter 2250-1)

849 IG-6.3 - - - 036080

Chuck

- 8 = 5/16", for taps
- 849 IG-M 8 up to M 12 (in conjunction with adapter 2250-3)

849 IG-8 - - - 036097

Die Stock

- drive 6,3 = 1/4", for dies 849 AG-M 3 up to M 6

849 AG-6.3 - - - 036004

Die Stock

- drive 10 = 3/8", for dies 849 AG-M 8 up to M 12

849 AG-10 - - - 035991

Hex Head Wrench

2100-025 2.5 - 58.5 20.5 011285

Adapter

- For manual operation
- With inside square and inside hexagon insert
- With clamping ball for bits

○ 6,3 = 1/4" - □ 6,3 = 1/4"

2250-1 23.5 - - 015443

○ 8 = 5/16" - □ 10 = 3/8"

2250-3 31 - - 015474

Thread Restorer



- For restoring damaged or worn-out inside or outside threads
- Surface: nickel-plated

HAZET No.	l mm	EAN-No. 4000896+

For threads M 5 to M 27

2126 230 012497